

CCMY8500M3 series four-inch coupler



01 CCMY8500M3 series four-inch coupler

The CCMY8500M3 Series Four-inch A.P.I. Coupler has been designed to comply with all the operational and test requirements of the EI Standard Specification(EI 1584) for Four-inch Hydrant system components and arrangements.

Operation

Four-inch Pressure Control Valve with deadman. This valve has been designed for use with aviation kerosenes and gasoline on refuelling vehicles. It regulates downstream pressure regardless of input pressure or flow rate and incorporates a deadman facility.The valve is air referenced and has a typical bias of 10-12 psi at full flow, (1000 lpm/1200 US gpm). The total pressure drop through the valve is approximately 14psi at 1000 Imp/1200 US gpm. A pressure relief valve between coupler and pressure control valve automatically breaks the hydraulic lock on closure of the coupler.

02 Key Features

- Rugged construction and robust design for long life
- Low weight
- Low pressure drop
- Adjustable smooth opening and closing characteristics
- High stability
- Qualified for E1 1584 4th edition requirements

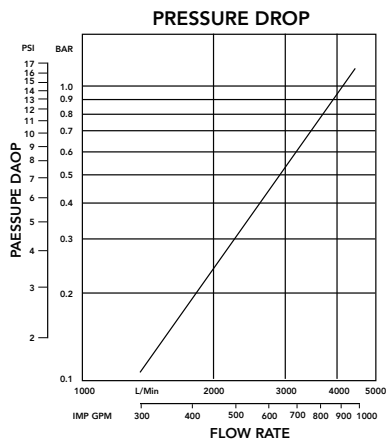

CCMY8500M3 series four-inch A.P.I. coupler

03 Operating Pressure Control

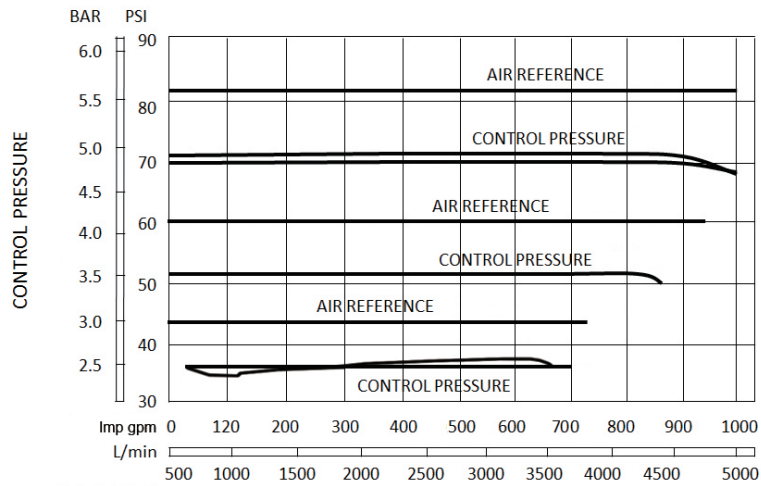

04 Dimensions

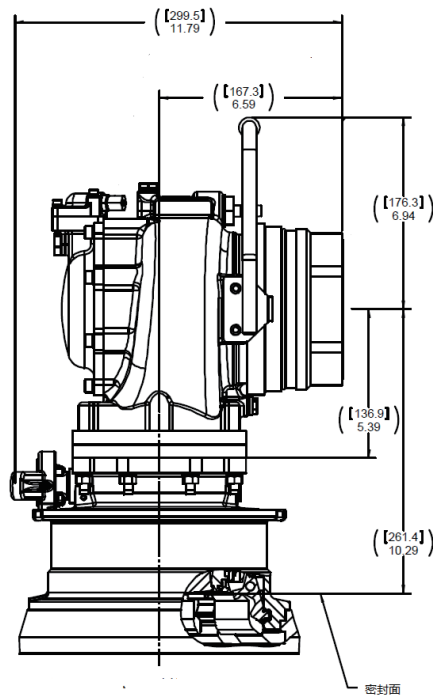

COUPLER WITH PRESSURE
CONTROL VALVE AND SWIVEL

CCMY8500M3 series four-inch A.P.I. coupler

05 General Information

COUPLER

POLYURETHANE BUMPER	Resists abrasion.
LOCKING AND INTERLOCKING	Positive connection between Pit Valve and Coupler by means of 6 catches. The poppet valve is prevented from opening when the Coupler is disconnected. The Coupler cannot be disconnected when the poppet valve is open.
EASY SERVICING	The Coupler may be completely dismantled and serviced from the A.P.I. end thus avoiding the need for removal from the pressure controller. The nose seal may be renewed while the unit is under system pressure.
ASSOCIATED EQUIPMENT	Pressure control valve with deadman. Construction throughout is mainly of high strength aluminium alloy and stainless steel. All wetted parts are of aluminium and stainless steel incorporating fuel resistant seals. All other components are protected against corrosion.
SMOOTH OPENING AND CLOSING	Approximately ten seconds to 'full flow'. Approximately five seconds to 'no flow'. Precise ramped closure prevents vacuum within coupler hose.
PRESSURE CONTROL	+ 2 psi
LOW BIAS TYPICALLY	10-12 psi
LOW HYSTERESIS	For details, see graphics in maintenance manual. Rapid response to surge pressures.
FAIL / SAFE	Valve will close even if controlling diaphragm ruptures.

Ground Fueling Products

CCMY8500M3 series four-inch A.P.I. coupler

06 Specification

WEIGHT, PRESSURES DROP, PRESSURE RATING	COUPLER	COUPLER Pressure Control Valve with Deadman & Swivel
WEIGHT	5.7Kg 12.5lbs	13kg 28lbs
PRESSURE DROP	-	less than 1.6 bar at 4500l/min less than 17psi at 1000Imp gpm-1200US gpm
PRESSURE DROP: MAX. WORKING	-	15bar 225psi
PRESSURE DROP: TEST PRESSURE	-	23bar 338psi
PRESSURE DROP: PROOF PRESSURE COUPLERS	-	76bar 1100psi

07 Ordering Information

CONFIGURATIONS	CODE NO.
COUPLER with short handle	CCMY 8500M3
with Trolley	add suffix T
Thead forms	add suffix B for BSP or N for NPT

08 Contact

Meggitt Shanghai Office

Address: Rm1107, Block A, No.319 XianXia Road, Changning District
Shanghai, China

Telephone: +86 21 6278 1096

Website: <https://www.meggitt.com/products-services/ground-fuelling>

Meggitt (Xiamen) Sensors & Control Co., Ltd.

Address: No. 230 South 5 Gaoqi Road, Xiamen 361006,
P.R. China

Telephone: +86 592 5733 666

Website: www.meggittxiamen.com/gfp