

Fuelling products

Coupling

1 1/2-inch self sealing industrial couplings

1 1/2-inch self sealing industrial couplings



Key Features

- Low cost
- Fail safe tank units
- Unrivalled quality for trouble free operation and long life
- Negligible spillage
- Environmentally friendly
- Easy single action coupling and valve opening
- Material: gunmetal
- Nitrile or fluorocarbon seals
- Seven selectivity options

GENERAL INFORMATION

Meggitt self sealing couplings are designed for use wherever it is necessary to connect and disconnect hoses and pipelines under pressure, quickly and without spillage. They are designed primarily for use in the petroleum and chemical industries where reliability and safety are of prime concern.

OPERATION

Operation is single action, using a straight forward turning motion to connect the couplings and open a flow path. An initial push and turn action on the hose unit causes engagement with the tank unit, thus locking and sealing the two units together. Further rotation causes the internal valves to open, thereby allowing flow with minimum pressure drop. The connection and valve mechanism is interlocked such that the valve can only be opened by fully engaging and sealing the hose unit on its matching tank unit. On disconnection, the valves fully close before the couplings separate and spillage is therefore negligible.

Meggitt Control Systems

Our product competencies & services:
 Aerospace valves | Thermal management solutions | Environmental control systems | Electro-mechanical products
 Ground fuelling products | Energy products | Aftermarket services

MEGGITT
 smart engineering for
 extreme environments

Fuelling products

Couplings

1 1/2-inch self sealing industrial couplings

Specification

1 - HOSE UNIT

CCMY 6153N*

1

Hexagon 2 1/4-inch (57mm) A/Flats

1 1/2-inch BSP(P)

Material	Gunmetal
Weight	2.2 kg (4.13 lb)
Max. Working Pressure	175 psi (12 bar)
Max. Coupling Pressure	60 psi (4 bar)
Test Pressure	265 psi (18 bar)

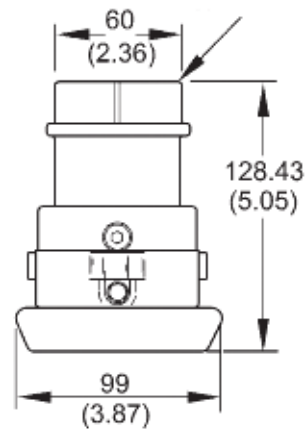

2 - As above,

2

Unit with Handle CCMY 6153NH

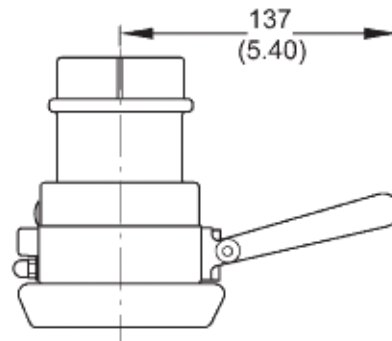

Meggitt Control Systems

Our product competencies & services:
Aerospace valves | Thermal management solutions | Environmental control systems | Electro-mechanical products
Ground fuelling products | Energy products | Aftermarket services

MEGGITT
smart engineering for
extreme environments