



Meggitt Fuelling Products

Avery-Hardoll
Whittaker Controls

1.5 and 2 inch stainless steel self-sealing couplings

with

cam operated hose units CCMY8153 and CCMY8154 series

and tank units CCMY8151, CCMY8152 (threaded) and CCMY8155 (flanged) series

Maintenance manual with spare parts list

Publication ref L002

Issue 8 July 2004

Avery-Hardoll
Holland Way
Blandford Forum
Dorset DT11 7BJ
UK

Tel: +44 (0) 1258 486600
Fax: +44 (0) 1258 486601

www.meggittfuelling.com

Whittaker Controls
12838 Saticoy St
North Hollywood
California 91605-3505
USA

Tel: +1 818 765 8160
Fax: +1 818 759 2194

www.wkr.com
www.meggitt.com

The information contained herein is the property of Avery Hardoll a division of Meggitt (UK) Ltd. No part may be reproduced or used except as authorised by contract or other written permission. The Company reserves the right to alter without notice the specification, design or conditions of supply of any product or service.

MEGGITT
smart engineering for
extreme environments

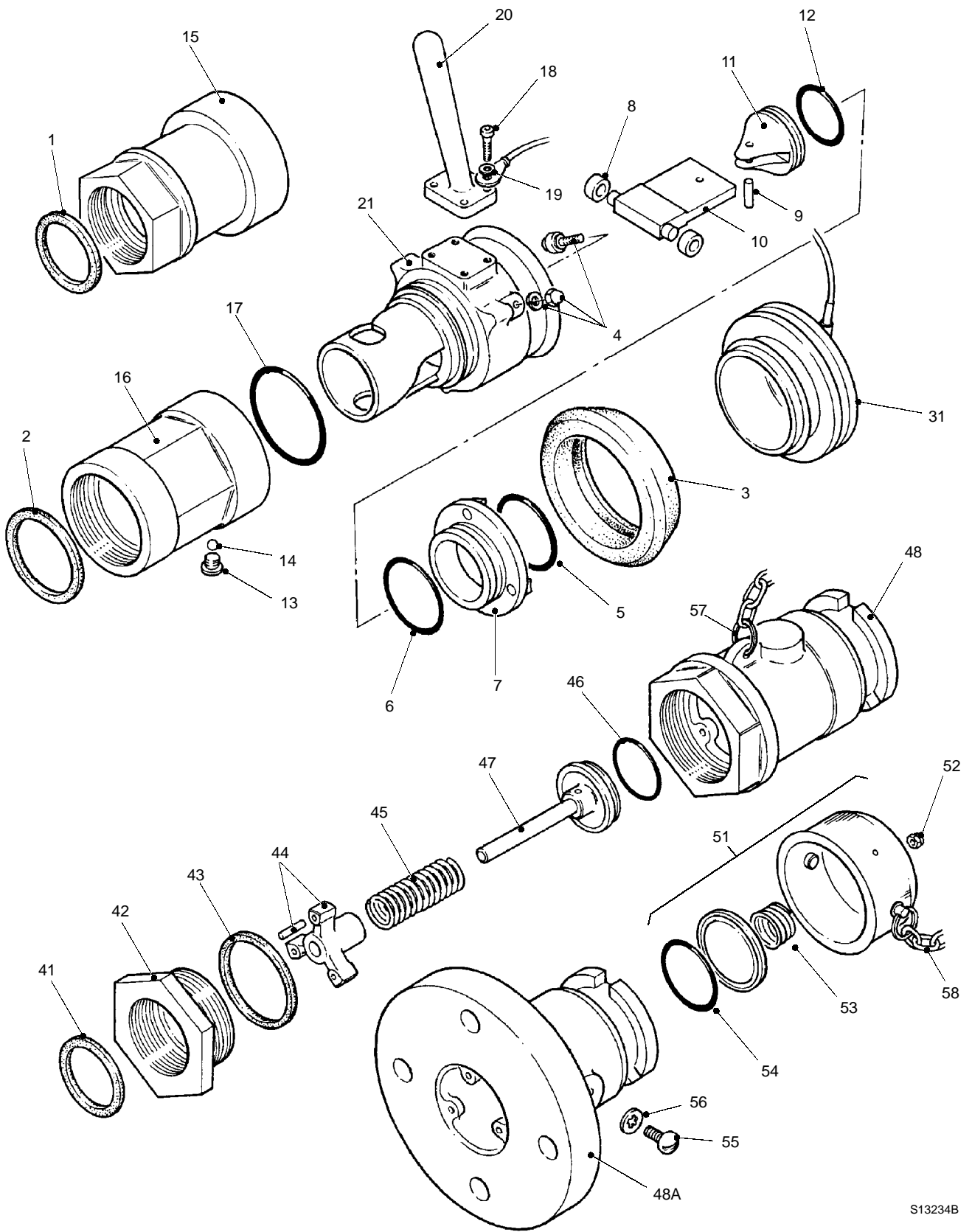

S13234B

Figure 1 1 1/2 and 2 inch stainless steel couplings with standard blanking caps

Spare parts identification and ordering

- The letters in the 'Use on' column in the following spares list are the part number suffix letters of the coupling to which the part should be fitted. Always quote the coupling part number in full, as well as the item part number when ordering spares.

Item	Part Number	Description	Use on	Qty
-	-	HOSE UNIT		Ref
1	CCRZ269-1	. Seal, connector 1 1/2 in. - Viton (Fluorocarbon)	V	1
	CCRZ269-2	. Seal, connector 1 1/2 in. - E.P.	E	1
	Z062E223139A	. Seal, connector 1 1/2 in. - Chemraz	C	1
	CCRZ269	. Seal, connector 1 1/2 in. - Nitrile	N	1
2	CCRZ8195V	. Seal, connector, 2 in. - Viton (Fluorocarbon)	V	1
	CCRZ8195E	. Seal, connector, 2 in. - E.P.	E	1
	Z062E227139A	. Seal, connector, 2 in. - Chemraz	C	1
	CCRZ8195N	. Seal, connector, 2 in. - Nitrile	N	1
3	CCRZ116	. Ring, buffer		1
4	CCMS8188	. Bayonet roller assy		3
5	ZARZ0041-40	. Seal, O-ring - Viton (Fluorocarbon)	V	1
	ZARZ0041-77	. Seal, O-ring - E.P.	E	1
	ZARZ0041-78	. Seal, O-ring - Chemraz	C	1
	ZARZ0041-7	. Seal, O-ring - Nitrile	N	1
6	Z032E224139A	. Seal, O-ring - Viton (Fluorocarbon)	V	1
	Z042E224139A	. Seal, O-ring - E.P.	E	1
	Z062E224139A	. Seal, O-ring - Chemraz	C	1
	Z022E224139A	. Seal, O-ring - Nitrile	N	1
7	CCMS8183	. Spanner ring assy		1
8	CCSZ8191	. Roller, cam		2
9	ZT4011M0516A	. Pin		1
10	CCSZ8178	. Rod, connecting		1
11	CCSZ8181	. Valve		1
12	Z032E218139A	. Seal, O-ring - Viton (Fluorocarbon)	V	1
	Z042E218139A	. Seal, O-ring - E.P.	E	1
	Z062E218139A	. Seal, O-ring - Chemraz	C	1
	Z022E218139A	. Seal, O-ring - Nitrile	N	1
13	CCSZ8194	. Plug		1
14	ZASZ0068-12	. Ball, 7/32 in. dia		35
15	CCSS8186	. Connector, hose - 1 1/2 in.		1
16	CCSS8182	. Connector, hose - 2 inch		1
17	Z032E227139A	. Seal, O-ring - Viton (Fluorocarbon)	V	1
	Z042E227139A	. Seal, O-ring - E.P.	E	1
	Z062E227139A	. Seal, O-ring - Chemraz	C	1
	Z022E227139A	. Seal, O-ring - Nitrile	N	1
18	ZS4025M04012A	. Screw	H	4
19	ZW4007M04A	. Washer, spring	H	4
20	CCSZ8184	. Handle	H	1
21	NOT SPARED	. Cam		Ref
31	CCMY324-1	Hose unit dust cap		1
-	-	TANK UNIT		Ref
41	CCRZ269-1	. Seal - Viton (Fluorocarbon)	V	1
	CCRZ269-2	. Seal - E.P.	E	1
	Z062E223139A	. Seal - Chemraz	C	1
	CCRZ269	. Seal - Nitrile	N	1
42	CCSZ8192	. Adaptor, 2 in to 1 1/2 in		1
43	CCRZ8195V	. Seal - Viton (Fluorocarbon)	V	1
	CCRZ8195E	. Seal - E.P.	E	1
	Z062E227139A	. Seal - Chemraz	C	1
	CCRZ8195N	. Seal - Nitrile	N	1
44	CCMS8176	. Guide assy		1
45	CCSZ223	. Spring		1
46	Z032E220139A	. Seal, O-ring - Viton (Fluorocarbon)	V	1
	Z042E220139A	. Seal, O-ring - E.P.	E	1
	Z062E220139A	. Seal, O-ring - Chemraz	C	1
	Z022E220139A	. Seal, O-ring - Nitrile	N	1
47	CCMS8198	. Valve assy		1
48	NOT SPARED	. Body, screwed		Ref
48 A	NOT SPARED	. Body, flanged		Ref
51	CCMY4VN	Tank unit blanking cap (with chain)		1
	CCMY4SP1	Tank unit blanking cap (with cable)		1
52	ZAXX0094-3	. Nut, Nyloc - 2BA		1
53	CCSZ55	. Spring		1
54	ZARZ0041-37	. Seal, O-ring - Viton (Fluorocarbon)		1
55	ZS4005M05008A	. Screw - M5		1
56	ZW4006M05A	. Washer, shakeproof		1
57	ZASZ0098-7	. Ring, key		1
58	CCMZ71	. Chain and jump link assy		1

General

- The 1¹/₂ and 2 inch stainless steel couplings are supplied in a range of seal materials and with optional selectivity to suit a particular application or customer requirement. The coupling build standard is indicated by the part number suffix letters:

1st suffix; C, E, N or V = seal material

2nd suffix; H = handle (optional)

2nd or 3rd suffix; ST, SU, SV, SW, SX, SY or SZ = selectivity (optional)

Data

- Working pressure (max) 300 psig (20.7 bar)
- Coupling pressure (no-flow conditions) 60 psig (4.1 bar)
- Static test pressure 450 psig (31 bar)
- Operating temperature range:
 - E.P. seals (Part No. suffix E) -45 to +120 deg C (-49 to +248 deg F)
 - Fluorocarbon (Viton) seals (Part No. suffix V) -20 to +120 deg C (-4 to +248 deg F)
 - Nitrile (Part No. suffix N) -30 to +120 deg C (-22 to +248 deg F)
 - Chemraz (Part No. suffix C) -29 to +232 deg C (-20 to +450 deg F)

Warning: Couplings fitted with E.P. seals (Part No. suffix 'E') must not be used to handle petroleum or kerosene products.

User Instructions

- Cleanliness is essential for trouble-free operation of the couplings. Always ensure that the blanking caps are installed when the units are disconnected for any length of time.
- Periodically examine the couplings for contamination, evidence of leakage and damage. Clean the couplings, as necessary, with lint-free cloth or a soft bristle brush moistened with a suitable cleaning agent; pay particular attention to the hose unit seal and the tank unit seal recess.

Repair

- Repair of the couplings is by replacement of faulty seals and worn or damaged components. Repair procedures are straightforward and no special tools are required. Refer to the exploded views and the following outline procedures for guidance.

Dismantling notes

- *Hose units:* Separate the hose unit (15 or 16) from the cam (21) by removing the plug (13) and rotating the cam to release the steel balls (14); collect the cam rollers (8). Remove the cap nuts and spring washers and remove the three bayonet roller assemblies (4) from the cam. Remove the spanner ring assy (7) and the valve components from the cam. Remove the pin (9) to separate the valve (11) from the connecting rod (10).
- *Tank units:* The valve in the tank unit is spring loaded and care must be taken to avoid injury when removing the valve guide assy. Push in and turn the valve guide (44) clear of the lugs in the valve body (48 or 48A), then carefully allow the spring to expand. Remove the guide, spring (45) and valve assy (47).

Cleaning and Inspection

- Clean all metal components using lint-free cloth moistened with a suitable non-toxic cleaning fluid. Ensure that residues of seal material are removed from O-ring seal grooves and from all sealing faces; use fine grade wire wool, if necessary. Do not remove fluoron coating from treated components.
- Examine all parts for damage, evidence of wear and condition of surface protection (Fluoron coated components). Discard unserviceable components together with all used seals and pins; refer to the spares list for replacement parts.

Assembling

- Assemble the units in the reverse order of dismantling and note the following:
- Exercise care when installing O-ring seals in 'dovetail' grooves; use a suitable lubricant if necessary, and wipe off any excess after assembly. Do not use petroleum jelly or liquid paraffin on E.P. seals.
- When installing the spanner ring assembly in the hose unit, ensure that the stops are positioned under the bayonet roller locations.
- Ensure that the handle (if fitted) is correctly orientated on the hose unit.
- After installing the guide assembly in the tank unit, check that the grooved pins are fully engaged in the retaining lugs in the body.
- The Nyloc nut securing the seal support plate in the tank unit blanking cap must be slackened approximately one turn to allow the seal plate to rotate in the cap.

Testing

- Couple the repair unit to a serviceable hose or tank unit as appropriate and check for correct operation of the valve actuating and bayonet locking mechanism. Couple and uncouple the unit(s) several times.